

THE CLEARVIEW[®]

Radi-Angle Form Dresser

Seeing
Is
Believing

Accuracy to .0001"

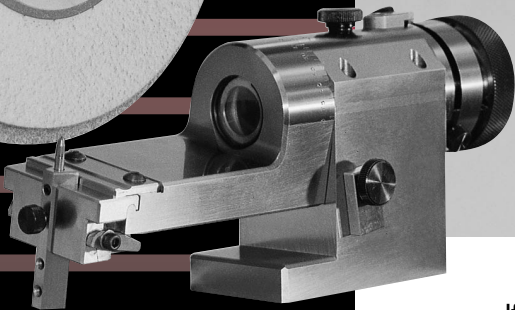

If you have ever spoiled a form while trying to dress a grinding wheel, you know just how frustrating it can be working "blindfolded". Most units on the market leave you guessing.

The Clearview[®] Radi-Angle Form Dresser manufactured by Kuhn Tool & Die Co. gets you up close and personal, leaving no doubt as to where the diamond point is in relation to the wheel. A powerful, specially ground magnifying lens allows you to see exactly what you are doing. A removable diamond slide located at the front of the swing arm allows you to set radii perfectly with gage blocks without touching the diamond on the blocks, and without removing the tool from the grinder.

Seeing is believing. Call now and order yours today.



373 Davis St. • P.O. Box 574 • Meadville, PA 16335 • PH: (814)336-2123
FAX: (814)336-2124 • www.kuhntool.com • EMAIL: info@kuhntool.com

THE CLEARVIEW[®]

Radi-Angle Form Dresser

S p e c i f i c a t i o n s

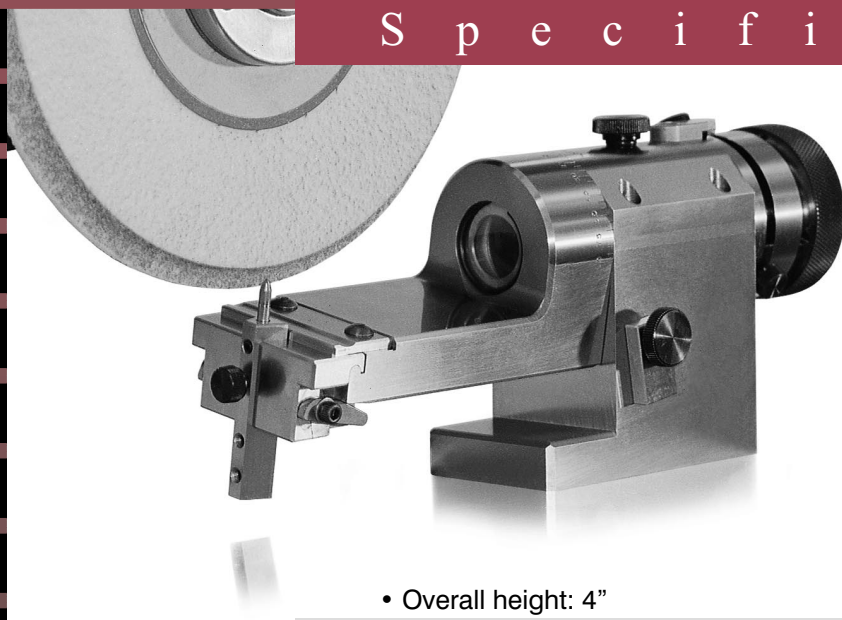

- Overall height: 4"
- Length: 8.25"
- 180° swing arm, graduated with vernier marking in 1° spacings.
- Maximum size grinding wheel 8" diameter*
- Maximum outside radius (on wheel) approximately 5/8"
- Maximum inside radius (on wheel) approximately 1"
- Spindle: 1" diameter O.D. hardened, ground and lapped.
Hand-fitted to insure perfect fit.
- Every CLEARVIEW[®] RADI-ANGLE DRESSER is tested and guaranteed for accuracy.
- Furnished with 90° phonopoint diamond in 1/8" shank.
- Packed in natural finished hardwood case.
- Shipping weight: 11 lbs.
- Optional at extra cost: 3/16" and 1/4" diamond holders
- Slide is hardened and lapped for optimum fit.
- We offer complete reconditioning services.
- Made in the U.S.A.

* 12" diameter wheel model available



373 Davis St. • P.O. Box 574
Meadville, PA 16335
PH: (814)336-2123 • FAX: (814)336-2124
www.kuhntool.com
EMAIL: info@kuhntool.com

Sold by: